

[ Special Series ]

# Haas VM Series

## The Vertical Mold Making Machines



Side-mount tool changer  
(24+1 tools) swaps tools  
in just 2.8 seconds

Inline direct-drive spindle features  
12,000 rpm and on-the-fly  
weye-delta switching



Specially designed table  
with T-slots in X and Y  
directions, plus precision  
dowel-pin bores and  
drilled & tapped holes.

Warranty: 1 Year Parts and Labor

### [ Standard Features ]

- 30 hp Vector Drive
- 12,000-rpm 40-Taper Spindle
- Inline Direct Drive
- 24+1 Side-Mount Tool Changer
- Programmable Coolant Nozzle
- 15" Color LCD Monitor w/USB Port
- High-Speed Machining w/Look-Ahead
- Rigid Tapping
- Ethernet Interface
- Chip Auger System
- Automatic Air Gun
- Coordinate Rotation & Scaling
- User-Definable Macros
- Enhanced Remote Jog Handle w/LCD
- Power Failure Detection Module
- 250 MB Program Memory
- Brushless Servos on All Axes
- Made in the USA



Haas Automation, Inc. | [www.HaasCNC.com](http://www.HaasCNC.com) | 800-331-6746 | Made in U.S.A.

Specifications subject to change without notice. Not responsible for typographical errors. Machines shown with optional equipment.



# Haas VM Series

## The Vertical Mold Making Machines

The Haas VM Series machines are high-performance VMCs that provide the accuracy, rigidity and thermal stability required for mold making, tool & die work and other high-precision industries. Each machine features a generous work cube, a multi-fixturing table and a 12,000-rpm inline direct-drive spindle. Standard features include the Haas high-speed control with full look-ahead, 24-pocket side-mount tool changer, programmable coolant nozzle, automatic air gun and much more.



For versatile fixturing, VM Series machines feature a specially designed table that has T-slots in both X and Y directions, as well as precision dowel-pin bores and a pattern of drilled & tapped holes.

The Haas-built 12,000-rpm inline direct-drive spindle, combined with the Haas high-speed control with full look-ahead, provides the accuracy and fine surface finishes mold makers and other high-precision industries demand.

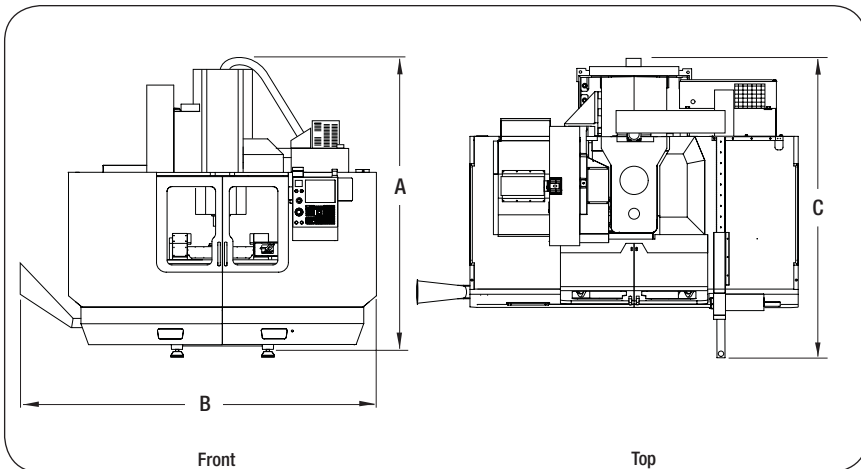

Operating Dimensions	VM-2	VM-3	VM-6
A. Max Operating Height	108" 2743 mm	124" 3150 mm	129" 3277 mm
B. Max Operating Width	122" 3099 mm	150" 3810 mm	178" 4521 mm
C. Max Operating Depth†	122" 3099 mm	135" 3429 mm	146" 3708 mm

† With control swung forward. Additional 36" (914 mm) required to open rear service panel.

### [ Specifications ]

Travels	VM-2	VM-3	VM-6
X	30" 762 mm	40" 1 016 mm	64" 1 626 mm
Y	20" 508 mm	26" 660 mm	32" 813 mm
Z	20" 508 mm	25" 635 mm	30" 762 mm

Table	VM-2	VM-3	VM-6
Length	36" 914 mm	54" 1 372 mm	64" 1 626 mm
Width	18" 457 mm	25" 635 mm	28" 711 mm
Max Weight on Table	3000 lb 1 361 kg	3500 lb 1 588 kg	4000 lb 1 814 kg

Spindle	VM-2	VM-3	VM-6
Speed	12,000 rpm		
Drive System	Inline Direct Drive		
Max Torque	75 ft-lb @ 2100 rpm 102 Nm @ 2 100 rpm		
Max Rating	30 hp 22.4 kW		

Brushless Axis Motors	VM-2	VM-3	VM-6
Max Thrust	3400 lb 15 124 N	5600 lb 24 910 N	3400 lb 15 124 N
X Axis	3400 lb 15 124 N	5600 lb 24 910 N	3400 lb 15 124 N
Y Axis	3400 lb 15 124 N	5600 lb 24 910 N	3400 lb 15 124 N
Z Axis	5600 lb 24 910 N	5600 lb 24 910 N	5600 lb 24 910 N

Feedrates	VM-2	VM-3	VM-6
Max Rapids	710 ipm 18.0 m/min	710 ipm 18.0 m/min	540 ipm 13.7 m/min
X Axis	710 ipm 18.0 m/min	710 ipm 18.0 m/min	600 ipm 15.2 m/min
Y Axis	710 ipm 18.0 m/min	710 ipm 18.0 m/min	600 ipm 15.2 m/min
Z Axis	500 ipm 12.7 m/min	500 ipm 12.7 m/min	500 ipm 12.7 m/min

Tool Changer	VM-2	VM-3	VM-6
Capacity	24+1 ( 40+1 optional)		
Tool Type/Taper	CT 40 (BT 40 optional)		
Max Tool Diameter	3.0" 76 mm		
Tool to Tool	2.8 sec		
Chip to Chip	3.6 sec		

Accuracy	VM-2	VM-3	VM-6
Positioning	±0.0002" ±0.005 mm	±0.0002" ±0.005 mm	±0.0003** ±0.008 mm
Repeatability	±0.0001" ±0.003 mm	±0.0001" ±0.003 mm	±0.0002** ±0.005 mm

General	VM-2	VM-3	VM-6
Machine Weight	7500 lb 3 402 kg	14,000 lb 6 350 kg	21,000 lb 9 526 kg

Power Required (min) 195 - 260 VAC 3-Phase

\* with linear scales



Specifications subject to change without notice. Not responsible for typographical errors. Machines shown with optional equipment.